



Zarf Tipi Paketlemede
Mükemmellik...

Excellence in
Over - Wrapping



AZZ 57 - SRV[®]

Servo Sistem Kutu Selefonlama Makinası

Servo System Box Overwrapping Machine

Tam Otomatik Zarf Tipi Sarmalama Makinaları
Full Automatic Over Wrapping Machinery Production

اوتوماتيكية كاملة في انتاج الات التغليف

www.unlumakinasan.com.tr





AZZ 57 - SRV[®]

Servo Sistem Kutu Selefonlama Makinası

Servo System Box Overwrapping Machine

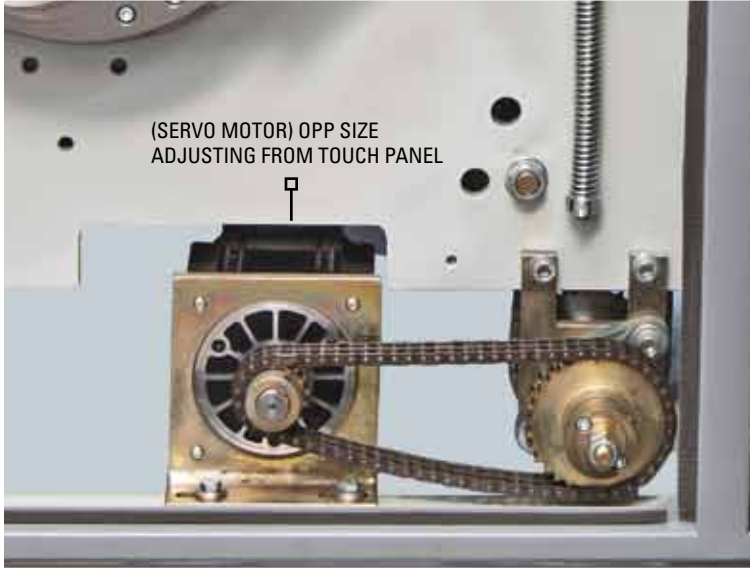

AZZ 57 - SRV[®]

Servo Sistem Kutu Selefonlama Makinası Servo System Box Overwrapping Machine

Kare ve dikdörtgen şeklindeki büyük hacimli kutuları tek parça veya sıra halinde sarmalamak için ideal ve kullanışlı bir makinedir. Besleme işlemi manuel olarak yapılabildiği gibi ürünün üretim hattından geliş şekline göre otomatik besleme de yapılabilir. Makinada OPP boy ayarı Servo Motor PLC ve dokunmatik ekran sistemi sayesinde otomatik olarak yapılır. Diğer kalıp değiştirme ayarları mekanik olarak kolay ve pratik bir şekilde yapılmaktadır. Makina ile ayrıca istenirse açma bandı aparatı takılarak paketlenmiş kutuların kolayca açılması sağlanır ve tarih - seri no yazma cihazıyla da selefonun üstüne tarih ve seri numara atılır.

An ideal machine for over-wrapping big size boxes as single box or multi-pack wrapping. The machine can be fed either manually or automatically from a production line. AZZ 57-SRV[®] machines have full automatic OPP Length adjustment features via servo motor PLC & 7.3" touch screen system. This machine is normally used by for big size boxes or for clinets who have many different boxes. Machine is very user friendly with easy & short change over from box to another. Tear tape applicator and date printer device are available on this machine upon request.

Packet Size Paket Ölçüleri	(A)		(B)	
	Min(mm)	Max (mm)	Min(mm)	Max (mm)
Length - Uzunluk	50	320	100	320
Width - Genişlik	35	150	100	225
Height - Yükseklik	20	100	20	50
OPP Length - Selefon Boyu	130	450	250	600
Capacity - Güç	15 - 35			
Power - Güç	5 KW, 380V - AC 3 Phase			
Weight - Ağırlık	950 kg			

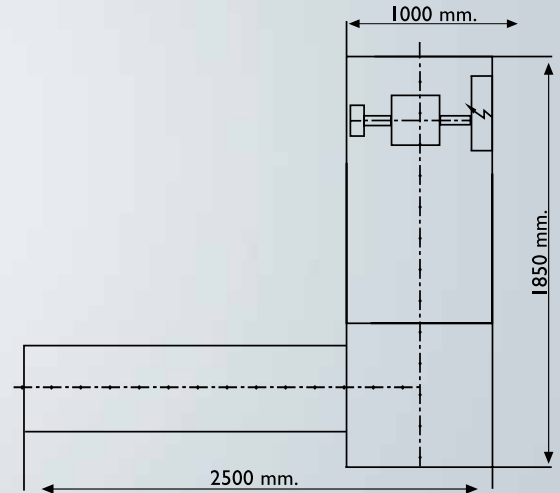
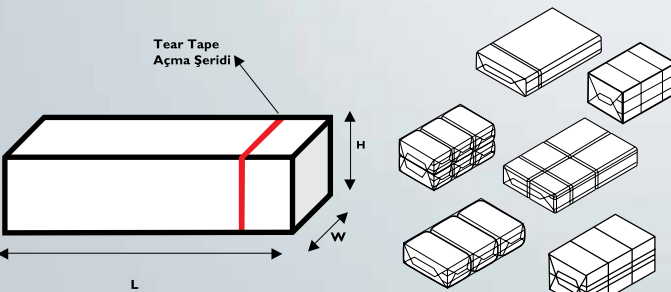

SUDE AJANS - 2016/03 © 0212.6120948



Madenler Durağı Meclis Mahallesi Teraziler Caddesi
PERPİM San. Sit. No:31 A Blok 5 Sancaktepe/İstanbul.TR
Telefon : +90 216 526 05 77 • Fax : +90 216 526 05 76
E-mail : info@unlumakinasan.com.tr

www.unlumakinasan.com.tr